

Fender Apron Panel Reinforcement

Special Tool(s) / General Equipment

6.5 mm Drill Bit
Polydrive Bit Socket
Self-Piercing Rivet (SPR) Remover/Installer
Belt Sander
Blind Rivet Gun
Hot Air Gun
Locking Pliers

Materials

Name	Specification
Metal Bonding Adhesive TA-1, TA-1-B, 3M™ 08115, LORD Fusor® 108B	-
Seam Sealer TA-2-B, 3M™ 08308, LORD Fusor® 803DTM	-

Removal

 **WARNING:** Electric vehicles damaged by a crash may have compromised high voltage safety systems and present a potential high voltage electrical shock hazard. Exercise caution and wear appropriate Personal Protective Equipment (PPE) safety gear, including high voltage safety gloves and boots. Remove all metallic jewelry, including watches and rings. Isolate the HV system as directed by the Ford Emergency Response Guide for the vehicle. Failure to follow these instructions may result in serious personal injury or death.

NOTICE: Battery electric vehicle (BEV), hybrid electric vehicle (HEV) and plug-in hybrid electric vehicle (PHEV) contain a high-voltage battery. Before cutting or welding near the high-voltage battery it must be removed to avoid damage.

-  **WARNING:** Before beginning any service procedure in this manual, refer to health and safety warnings in section 100-00 General Information. Failure to follow this instruction may result in serious personal injury.

Refer to: [Health and Safety Precautions](#) (100-00 General Information, Description and Operation).

Refer to: [High Voltage System Health and Safety Precautions - Overview](#) (100-00 General Information, Description and Operation).

NOTE: Aluminum body panels are highly receptive to heat transfer. With the extensive use of structural adhesives and non-structural sealers used in vehicle construction, the potential of heat transfer could impact adhesives and sealers in non-associated panels during the repair process. Many repairs areas that utilize

structural adhesive may be separated after fastener removal by using a panel chisel along the joint/flange. Using heat not exceeding 425° F to loosen a bonded panel should only be done when **all panels in the joint** will be replaced and new adhesive applied.

NOTE: The fender apron panel reinforcement must be replaced at the factory seams. No sectioning procedure is approved or permitted.

NOTE: Left hand (LH) side shown, right hand (RH) side similar.

2. Depower the **SRS**.

Refer to: [Supplemental Restraint System \(SRS\) Depowering](#) (501-20B Supplemental Restraint System, General Procedures).

3. Remove the air cleaner assembly.

Refer to: [Air Cleaner](#) (303-12A Intake Air Distribution and Filtering - 2.7L EcoBoost (238kW/324PS), Removal and Installation).

Refer to: [Air Cleaner](#) (303-12B Intake Air Distribution and Filtering - 3.3L Duratec-V6, Removal and Installation).

Refer to: [Air Cleaner](#) (303-12E Intake Air Distribution and Filtering - 5.0L 32V Ti-VCT, Removal and Installation).

Refer to: [Air Cleaner](#) (303-12E Intake Air Distribution and Filtering - 5.0L 32V Ti-VCT, Removal and Installation).

Refer to: [Air Cleaner](#) (303-12F Intake Air Distribution and Filtering - 3.0L Power Stroke Diesel, Removal and Installation).

4. Remove the front bumper.

Refer to: [Front Bumper](#) (501-19 Bumpers, Disassembly and Assembly).

5. Remove the hood and hood hinge on the repair side.

Refer to: [Hood](#) (501-02 Front End Body Panels, Removal and Installation).

6. LH side.

Refer to: [Battery](#) (414-01 Battery, Mounting and Cables, Removal and Installation).

7. Remove the fender and fender splash shield.

Refer to: [Fender](#) (501-02 Front End Body Panels, Removal and Installation).

Refer to: [Fender Splash Shield](#) (501-02 Front End Body Panels, Removal and Installation).

8. Remove the front door.

Refer to: [Front Door - Regular Cab/SuperCrew](#) (501-03 Body Closures, Removal and Installation).

Refer to: [Front Door - SuperCab](#) (501-03 Body Closures, Removal and Installation).

9. Verify the vehicle is dimensionally correct.

Refer to: [Body and Frame](#) (501-26 Body Repairs - Vehicle Specific Information and Tolerance Checks, Description and Operation).

10. Position aside the wiring harness.

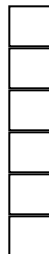

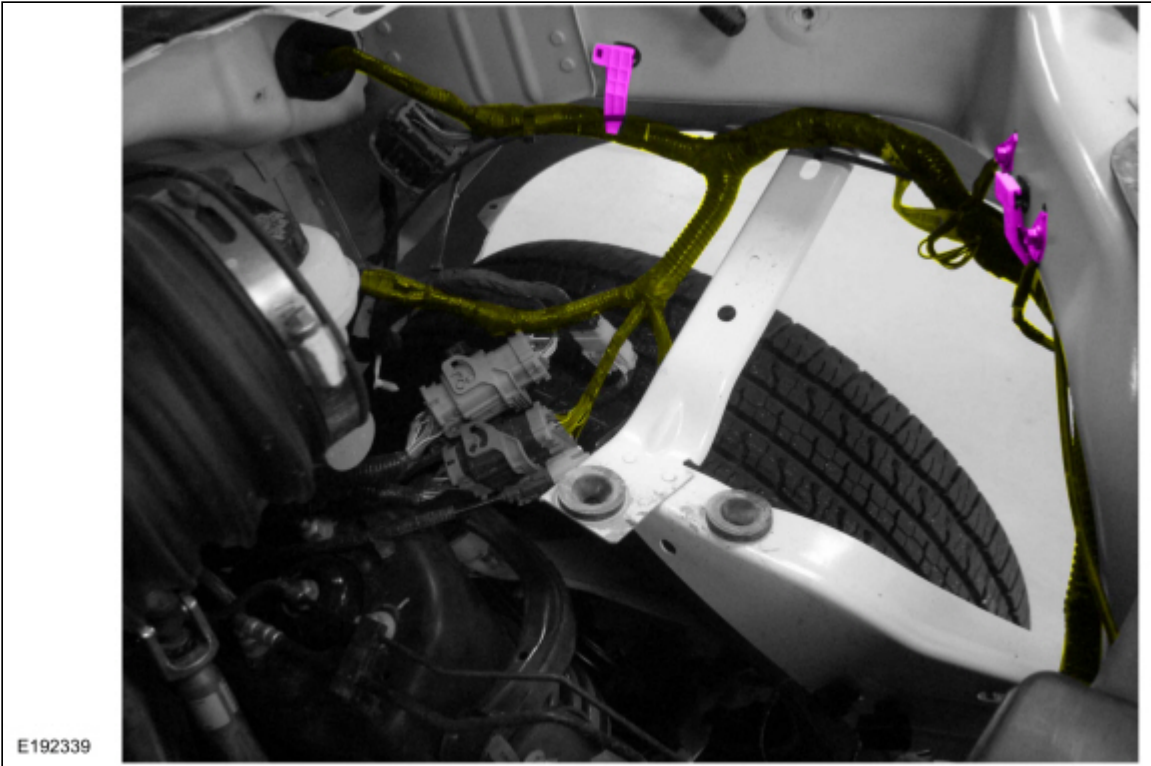

11. Remove the lower fender bracket.



<input type="checkbox"/>
<input type="checkbox"/>
<input type="checkbox"/>
<input type="checkbox"/>
<input type="checkbox"/>
<input type="checkbox"/>
<input type="checkbox"/>



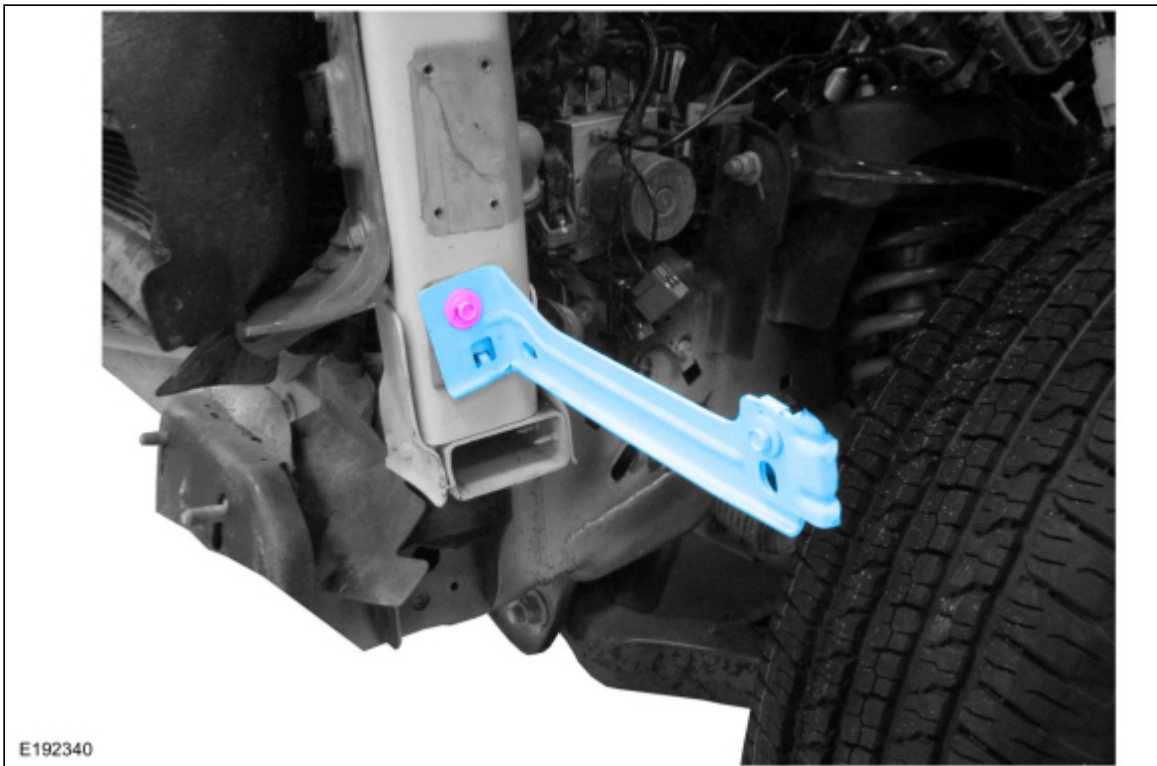

12. Remove the cooling module.

Refer to: [Cooling Module](#) (303-03A Engine Cooling - 2.7L EcoBoost (238kW/324PS), Removal and Installation).

Refer to: [Cooling Module](#) (303-03F Engine Cooling - 3.0L Power Stroke Diesel, Removal and Installation).

Refer to: [Cooling Module](#) (303-03B Engine Cooling - 3.3L Duratec-V6, Removal and Installation).

Refer to: [Cooling Module](#) (303-03C Engine Cooling - 3.5L EcoBoost (BM), Removal and Installation).

Refer to: [Cooling Module](#) (303-03D Engine Cooling - 3.5L V6 PowerBoost (CN), Removal and Installation).

13. Remove and discard the FDS fasteners.

Use the General Equipment: Polydrive Bit Socket



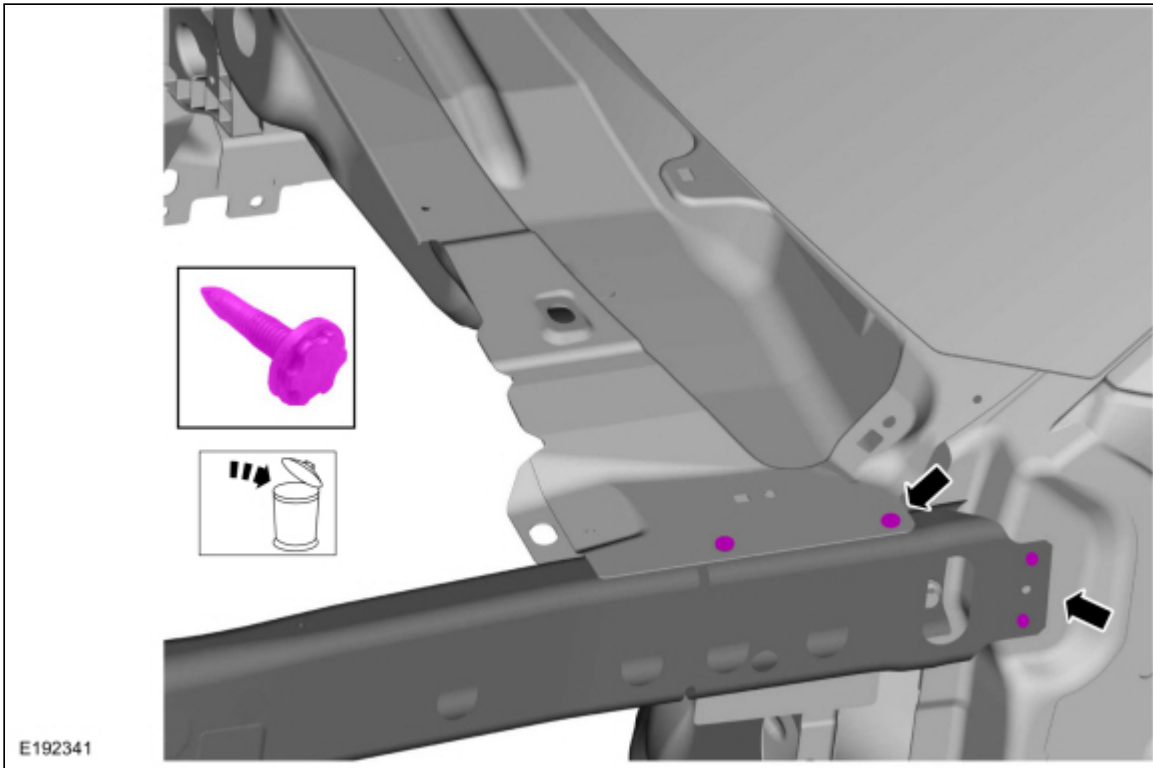

14. Remove the bolts.





15. Remove the SPR fasteners.
Use the General Equipment: Self-Piercing Rivet (SPR) Remover/Installer
Use the General Equipment: Belt Sander



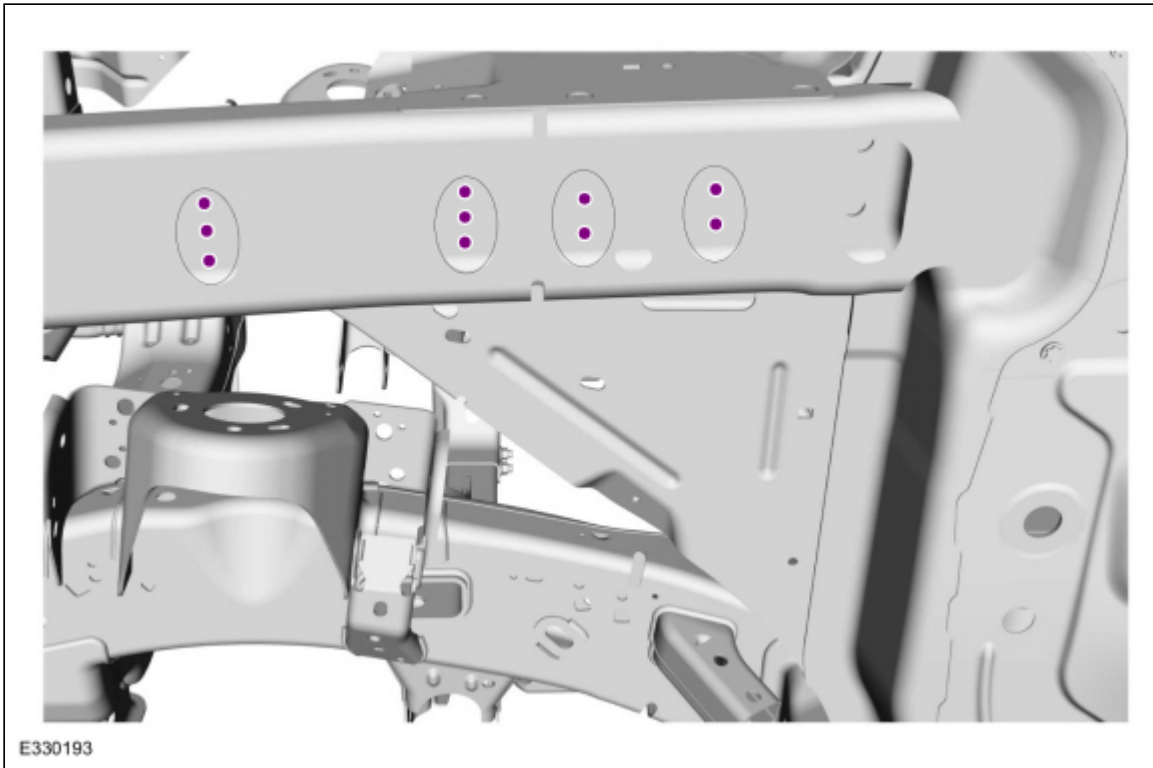

- 16. Remove the FDS and SPR fasteners.
Use the General Equipment: Polydrive Bit Socket
Use the General Equipment: Self-Piercing Rivet (SPR) Remover/Installer
Use the General Equipment: Belt Sander



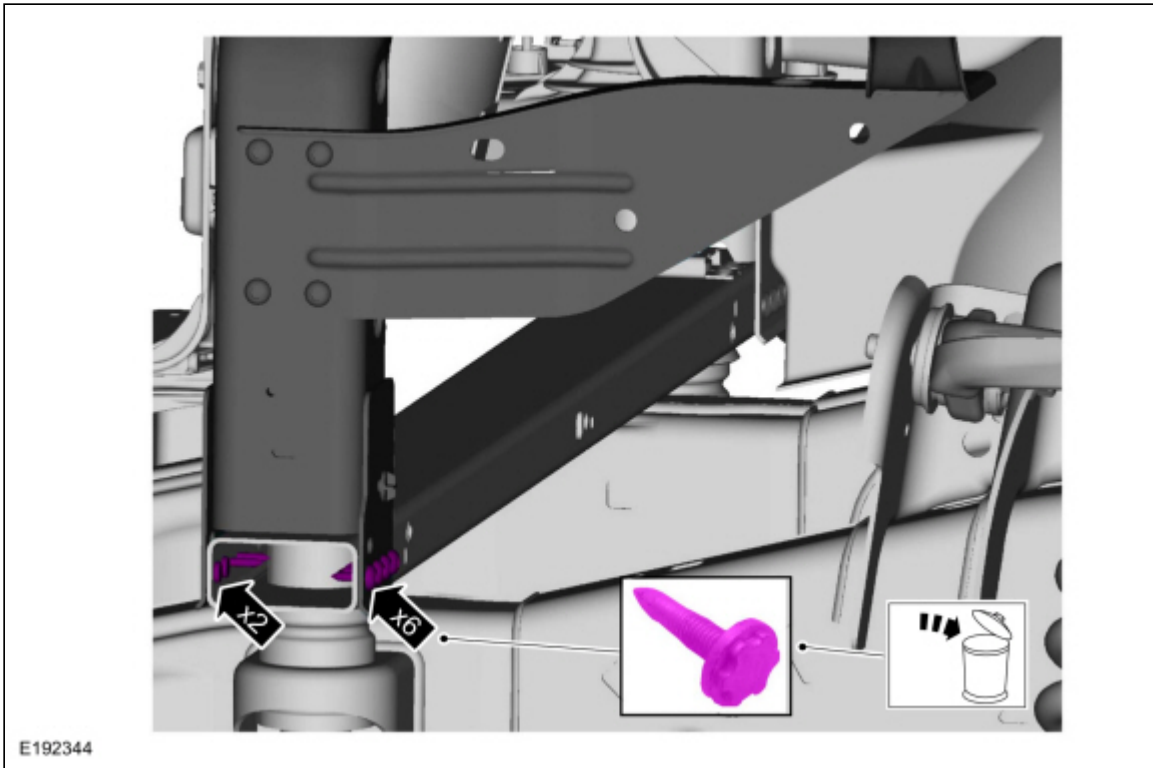

17. Remove the radiator bolster bolts.



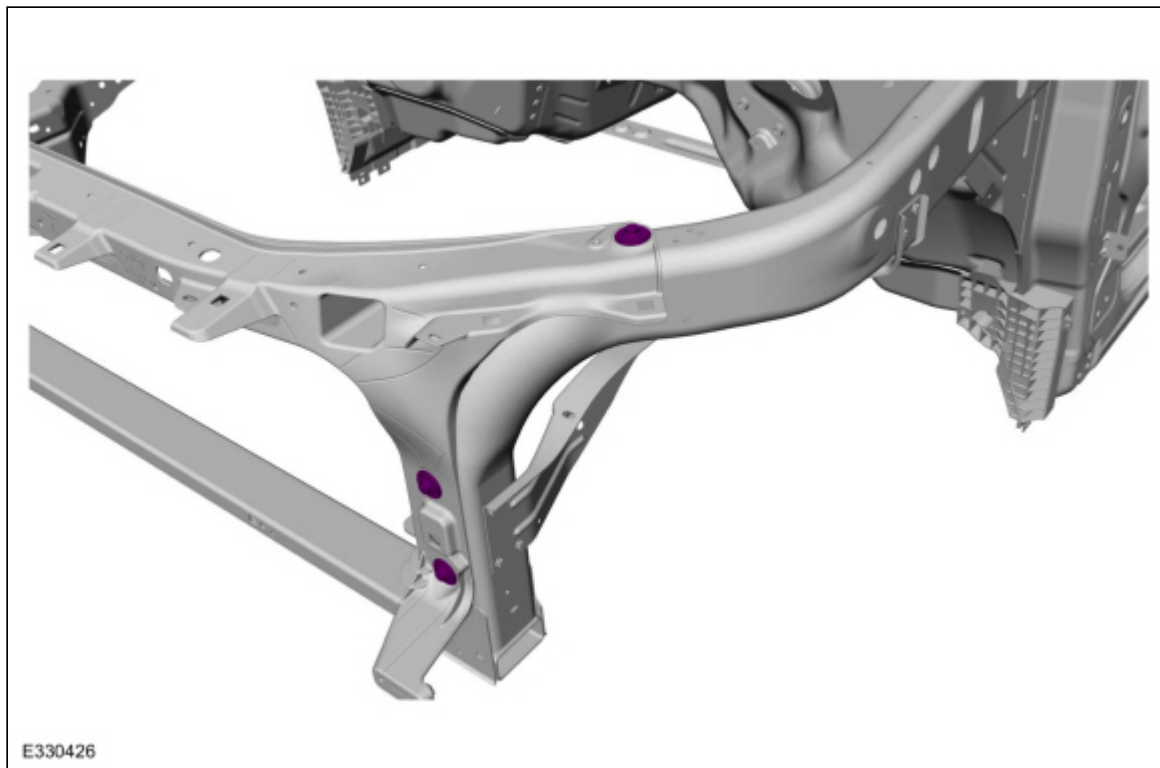

18. **NOTE:** Aluminum body panels are highly receptive to heat transfer. With the extensive use of structural adhesives and non-structural sealers used in vehicle construction, the potential of heat transfer could impact adhesives and sealers in non-associated panels during the repair process. Many repairs areas that utilize structural adhesive may be separated after fastener removal by using a panel chisel along the joint/flange. Using heat not exceeding 425° F to loosen a bonded panel should only be done when **all panels in the joint** will be replaced and new adhesive applied.

Remove the fender apron panel reinforcement.
Use the General Equipment: Hot Air Gun



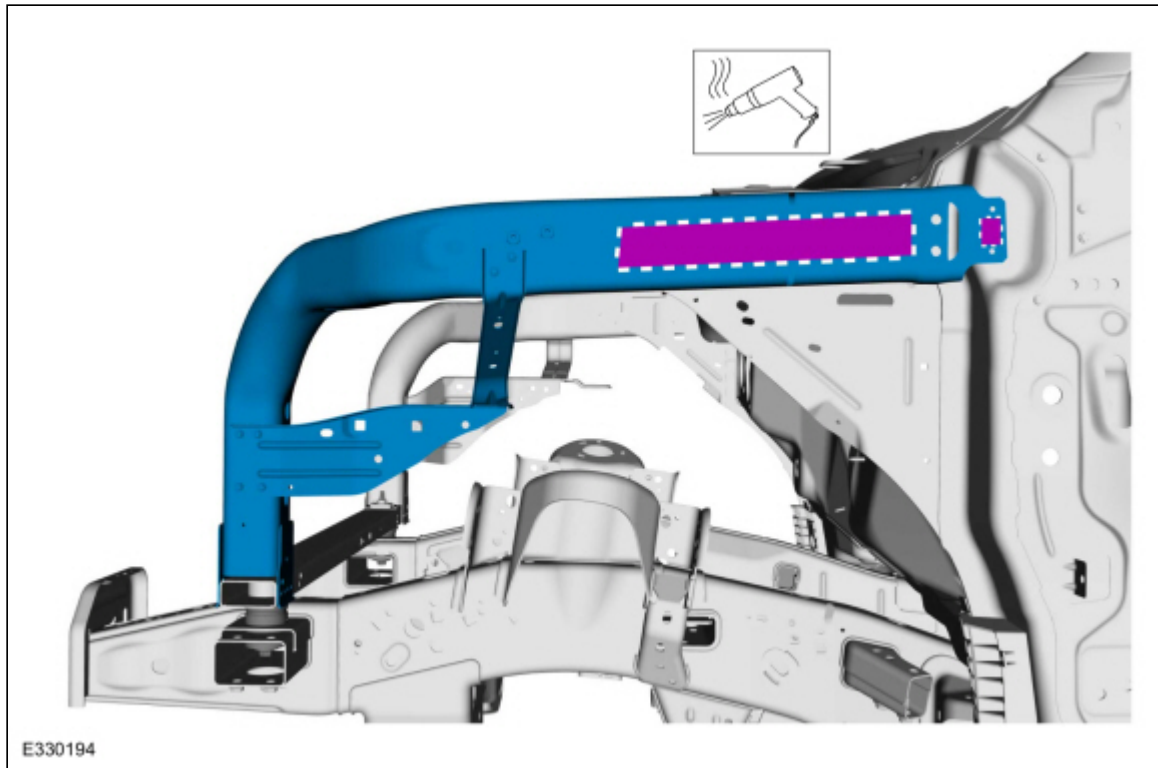

Installation

NOTE: *The fender apron panel reinforcement must be replaced at the factory seams. No sectioning procedure is approved or permitted.*

NOTE: *LH side shown, RH side similar.*

1. Sand to remove old adhesive using 80 grit sandpaper and clean.

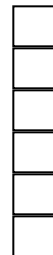

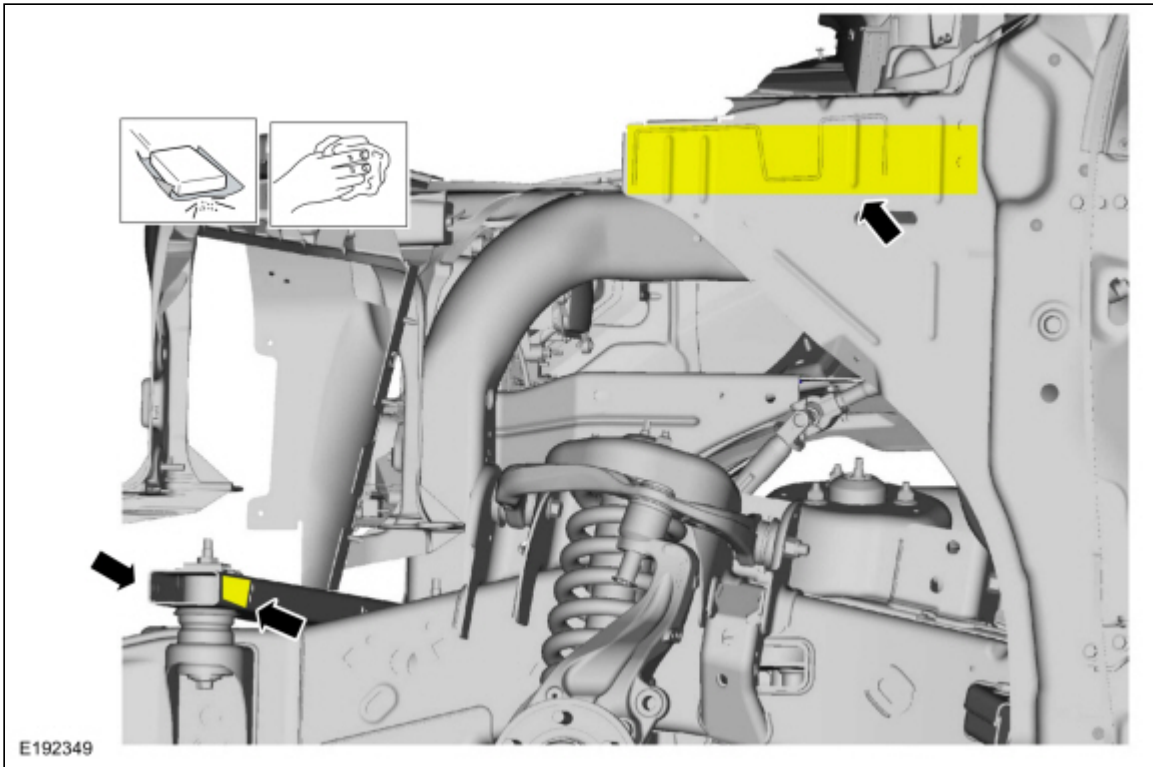

2. Sand to remove e-coat **in the mating surface area only** using 80 grit sandpaper and clean.

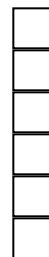

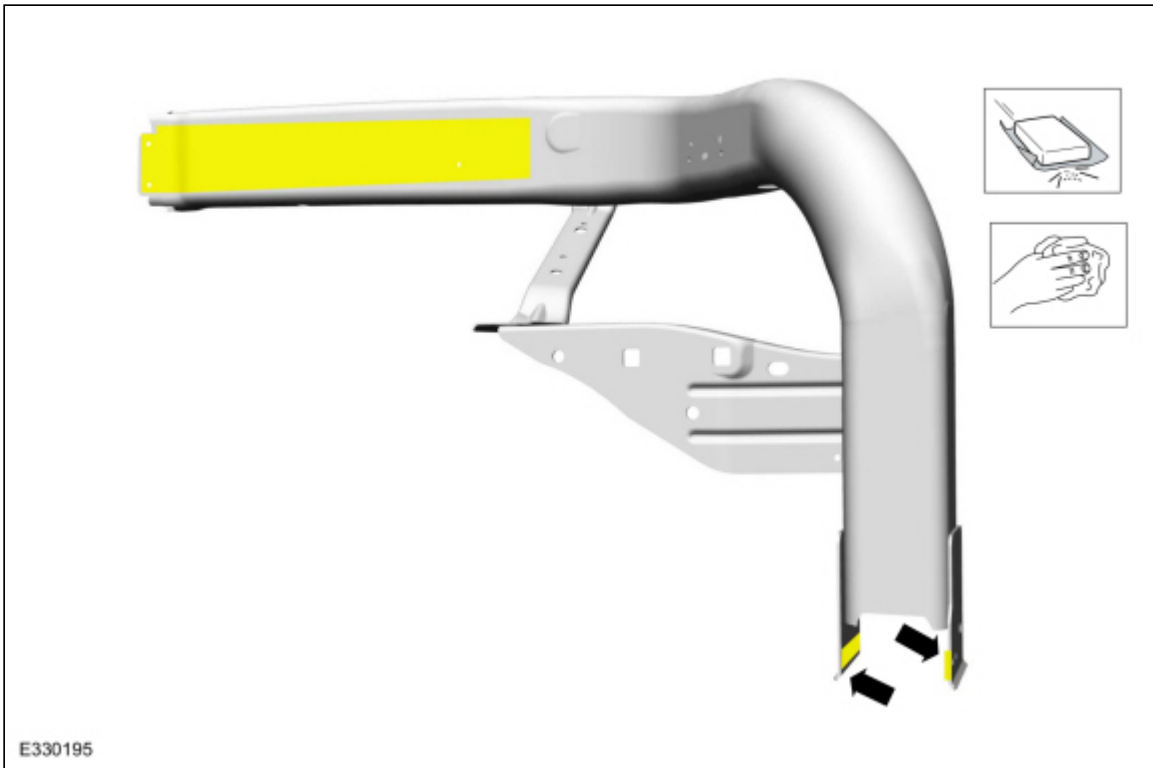

3. Apply adhesive.

Material: Metal Bonding Adhesive / TA-1, TA-1-B, 3M™ 08115, LORD Fusor® 108B

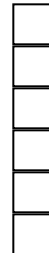

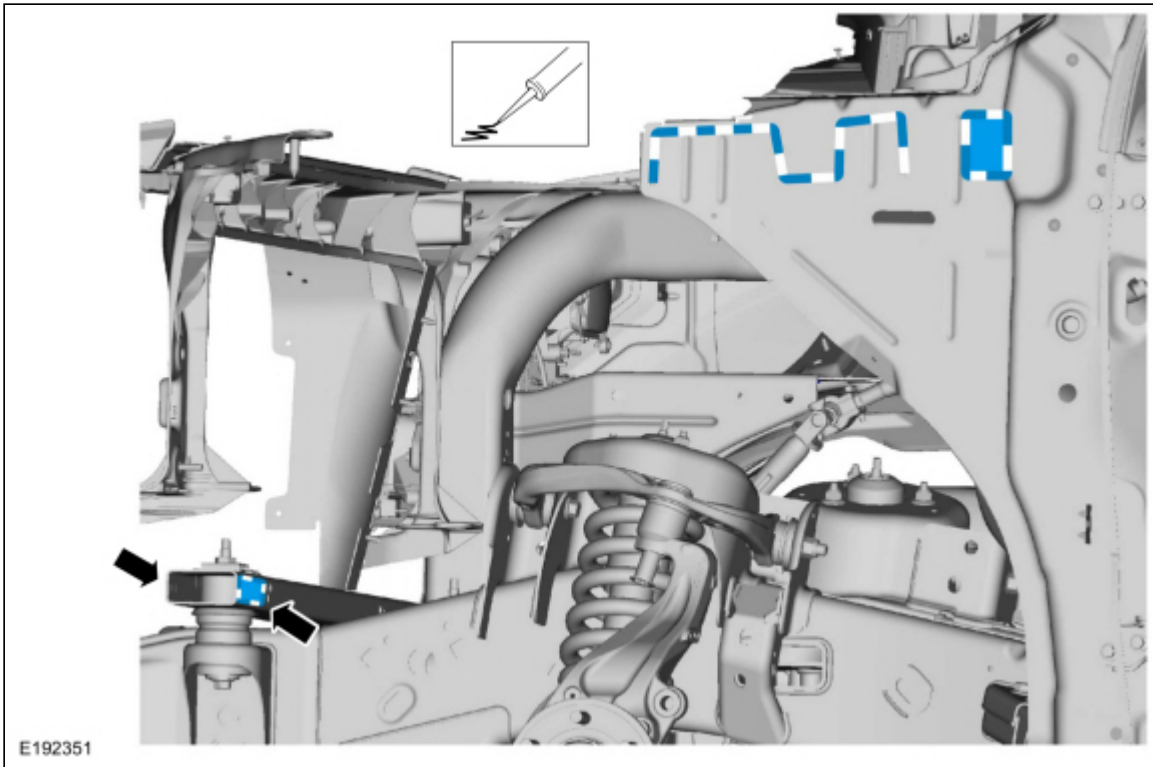

- 4. Install, properly position and clamp the fender apron panel reinforcement assembly.
Use the General Equipment: Locking Pliers



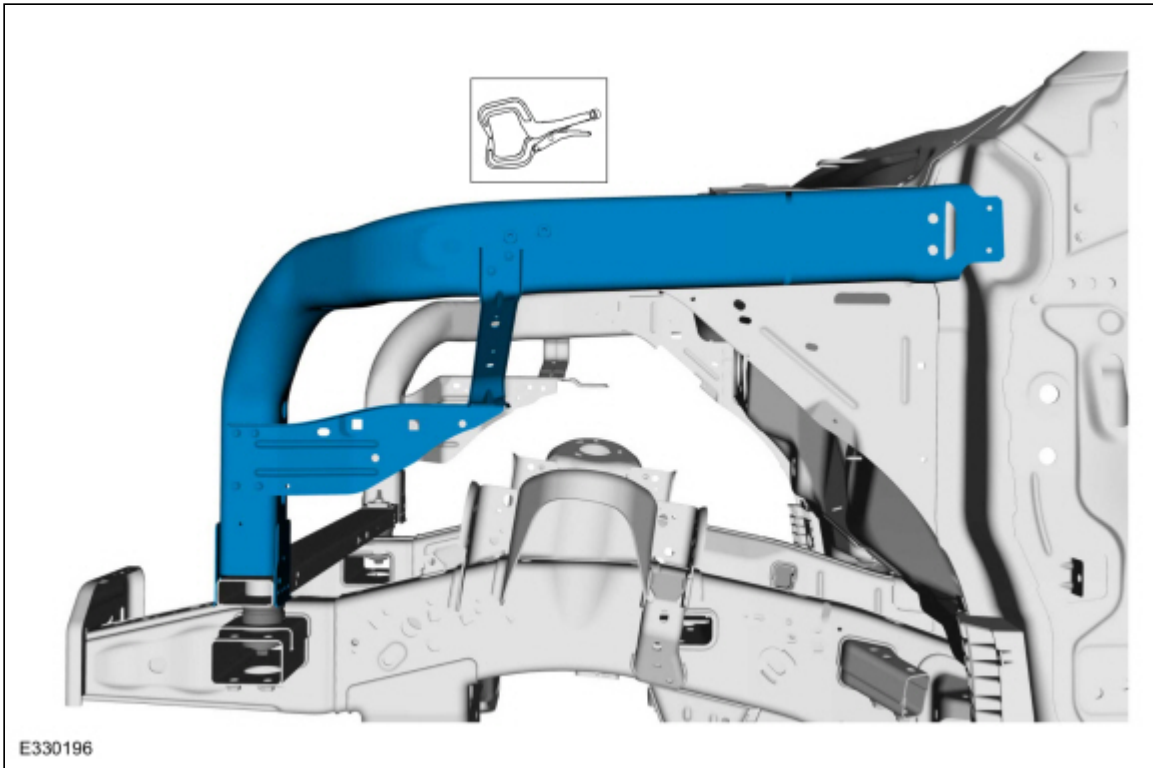

- 5. Install the bolts.
Torque: 22 lb.ft (30 Nm)



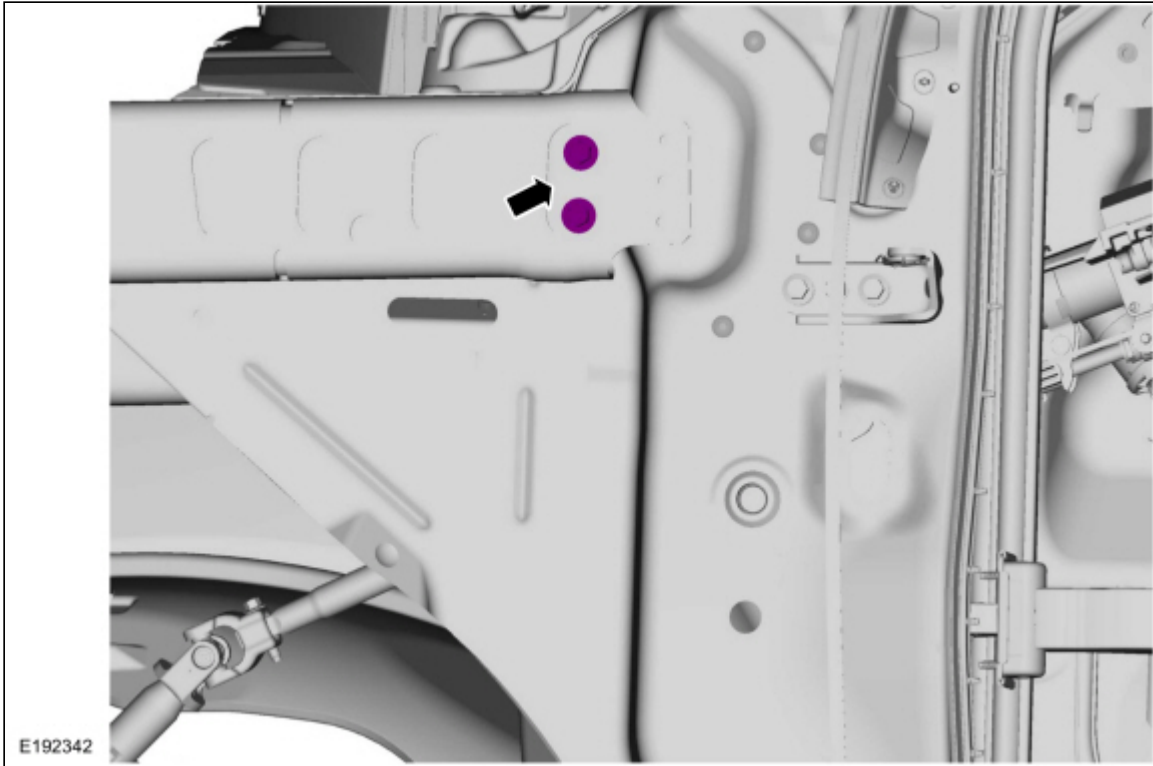

- 6. Drill rivet holes as indicated.
Use the General Equipment: 6.5 mm Drill Bit



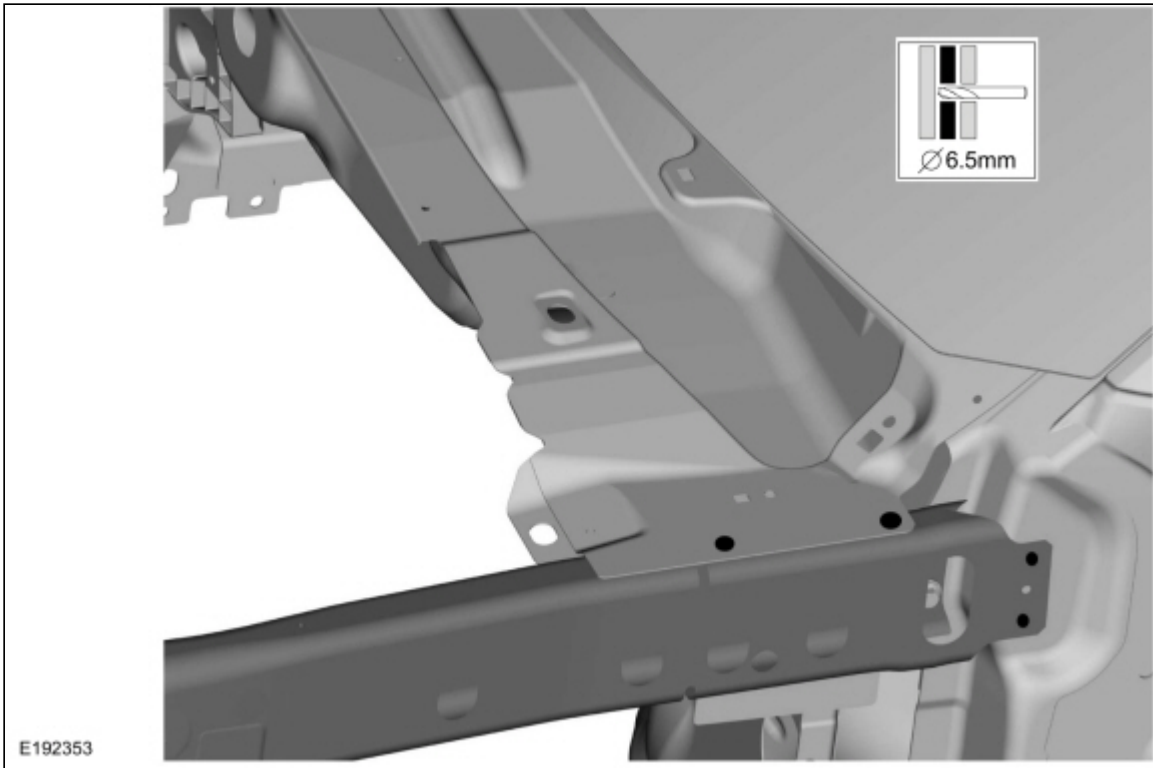

7. Install blind rivet fasteners.

Item	SPR Number	SPR Code	Henrob®, Car-OLiner®, CMO®, Chief®, Spanesi®, Wielander and Schill® Mandrel	Pro-Spot® Mandrel	Blind Rivet	Solid Rivet	Rivnut®
1	-	-	-	-	W708777-S900C	-	-
2	-	-	-	-	W702512-S900C	-	-

Use the General Equipment: Blind Rivet Gun



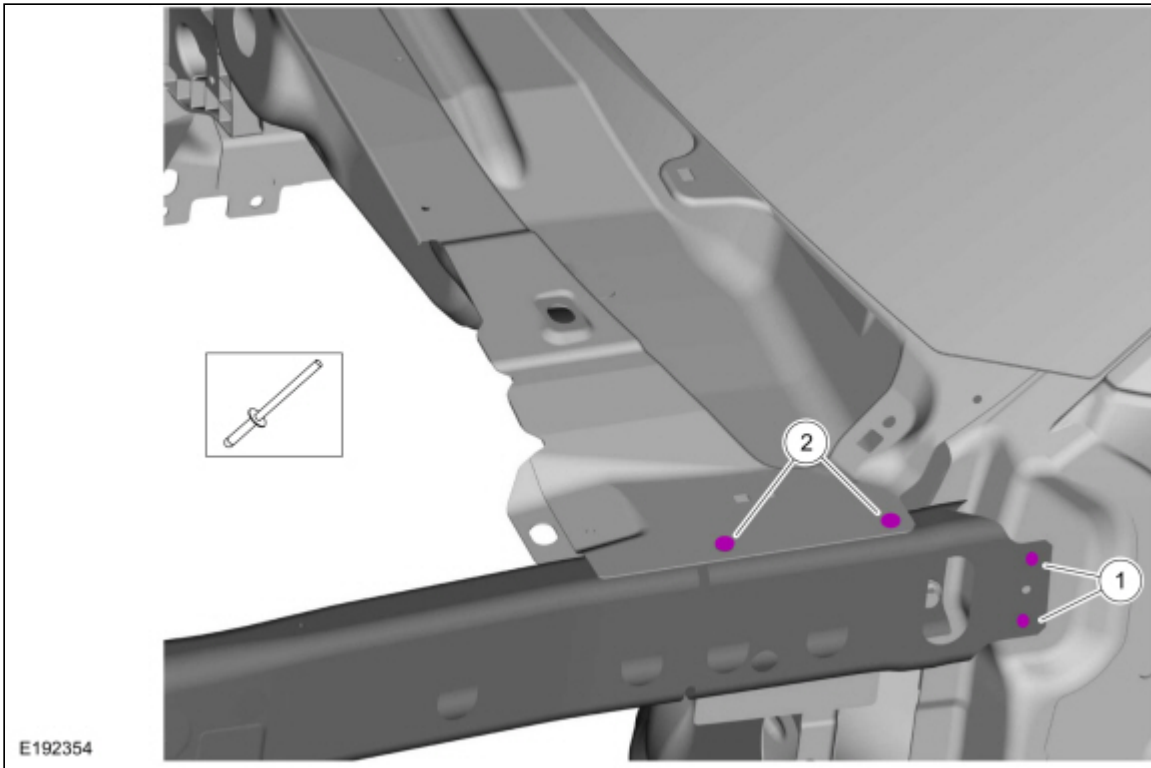

- 8. Drill rivet holes as indicated.
Use the General Equipment: 6.5 mm Drill Bit



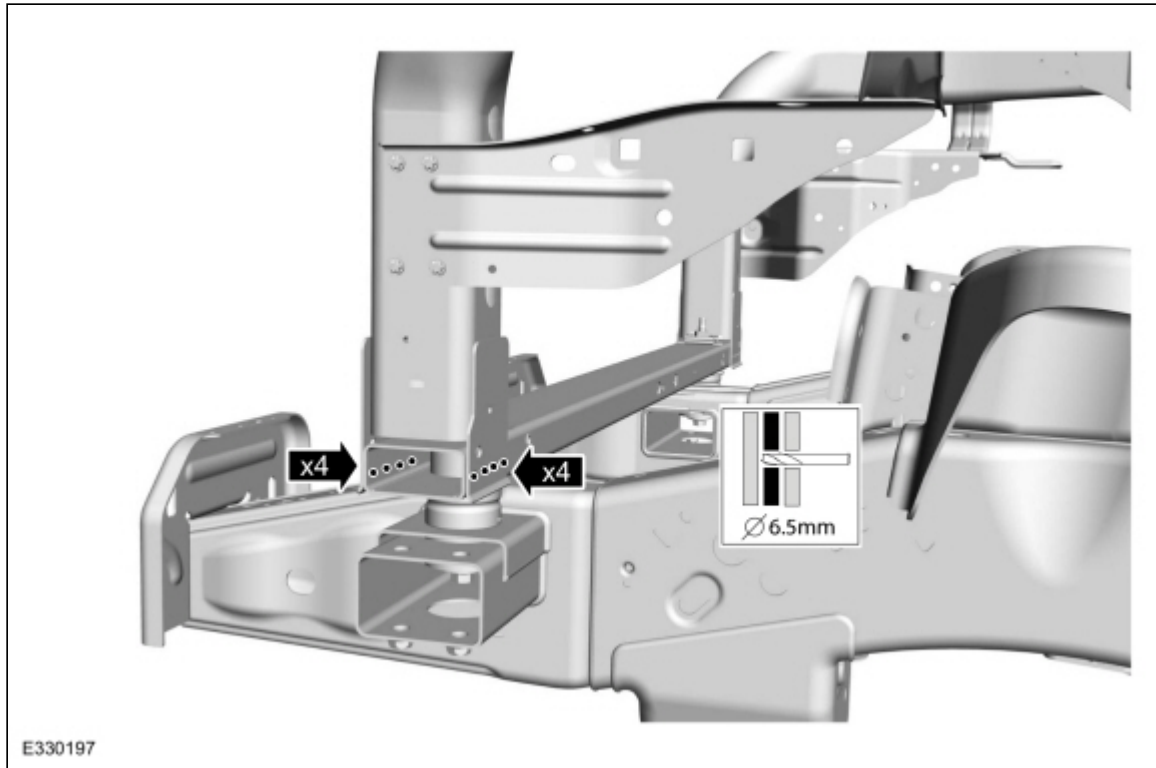

9. Install blind rivet fasteners.

Item	SPR Number	SPR Code	Henrob®, Car-OLiner®, CMO®, Chief®, Spanesi®, Wielander and Schill® Mandrel	Pro-Spot® Mandrel	Blind Rivet	Solid Rivet	Rivnut®
1	-	-	-	-	W708777-S900C	-	-

Use the General Equipment: Blind Rivet Gun



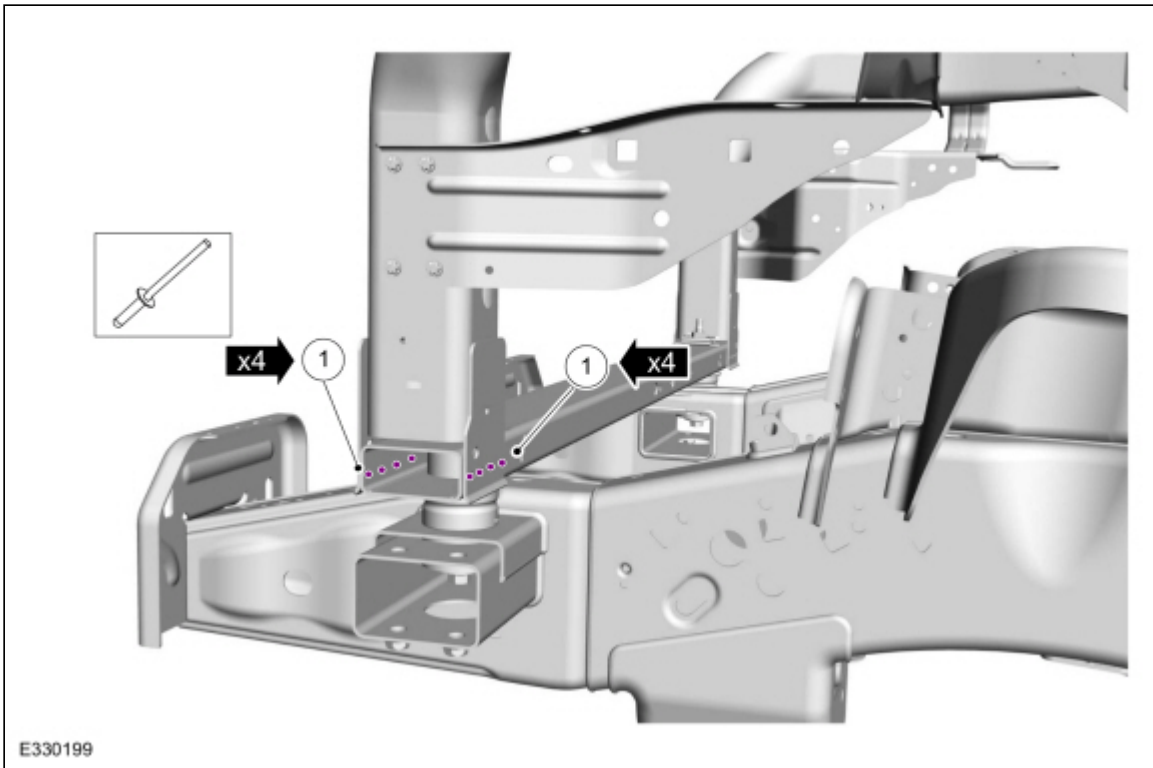

- 10. Drill rivet holes as indicated.
Use the General Equipment: 6.5 mm Drill Bit

□
?
?
?
?
?
?
?
?

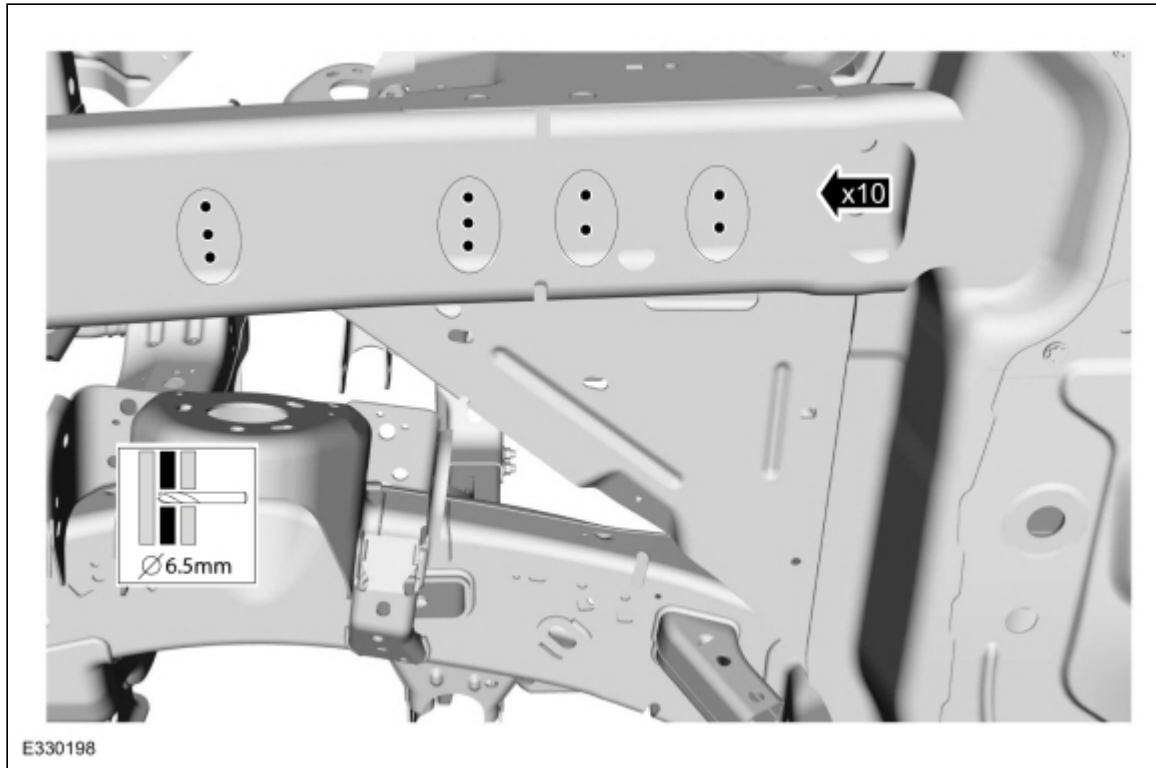

11. Install blind rivet fasteners.

Item	SPR Number	SPR Code	Henrob®, Car-OLiner®, CMO®, Chief®, Spanesi®, Wielander and Schill® Mandrel	Pro-Spot® Mandrel	Blind Rivet	Solid Rivet	Rivnut®
1	-	-	-	-	W708777-S900C	-	-

Use the General Equipment: Blind Rivet Gun



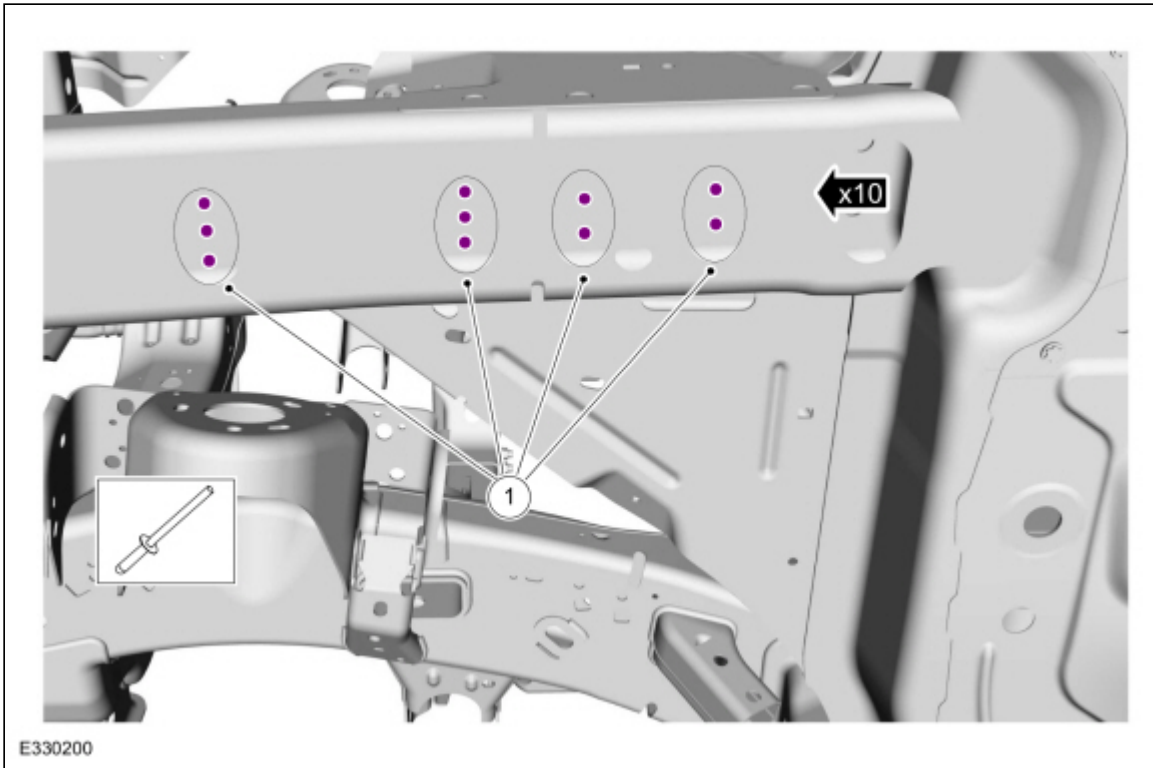

- 12. Install the bolts.
Torque: 22 lb.ft (30 Nm)

□
?
?
?
?
?
?
?
?

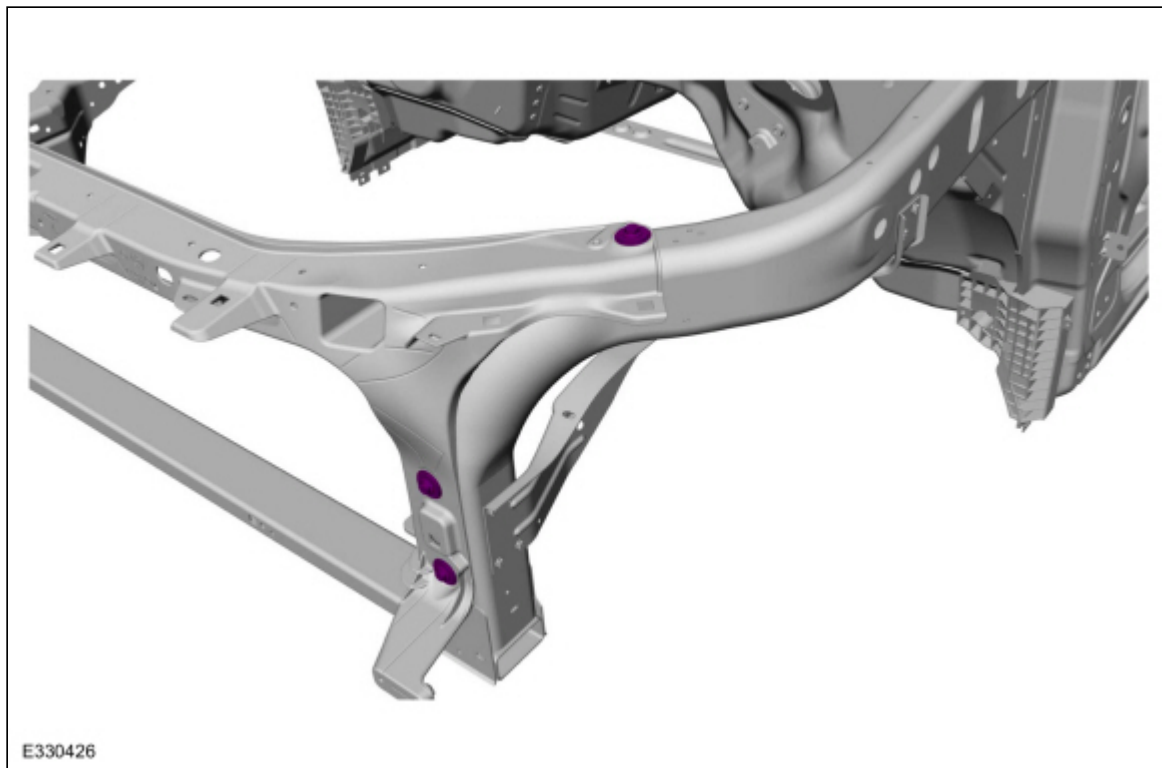

13. Sealing work: All areas must be sealed to production level.

Material: Seam Sealer / TA-2-B, 3M™ 08308, LORD Fusor® 803DTM

14. Refinish the repair using a Ford approved paint system and typical refinishing techniques.

15. Install the radiator assembly.

Refer to: [Cooling Module](#) (303-03A Engine Cooling - 2.7L EcoBoost (238kW/324PS), Removal and Installation).

Refer to: [Cooling Module](#) (303-03F Engine Cooling - 3.0L Power Stroke Diesel, Removal and Installation).

Refer to: [Cooling Module](#) (303-03B Engine Cooling - 3.3L Duratec-V6, Removal and Installation).

Refer to: [Cooling Module](#) (303-03C Engine Cooling - 3.5L EcoBoost (BM), Removal and Installation).

Refer to: [Cooling Module](#) (303-03D Engine Cooling - 3.5L V6 PowerBoost (CN), Removal and Installation).

16. Install the lower fender bracket.

Torque: 80 lb.in (9.0 Nm)



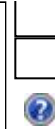
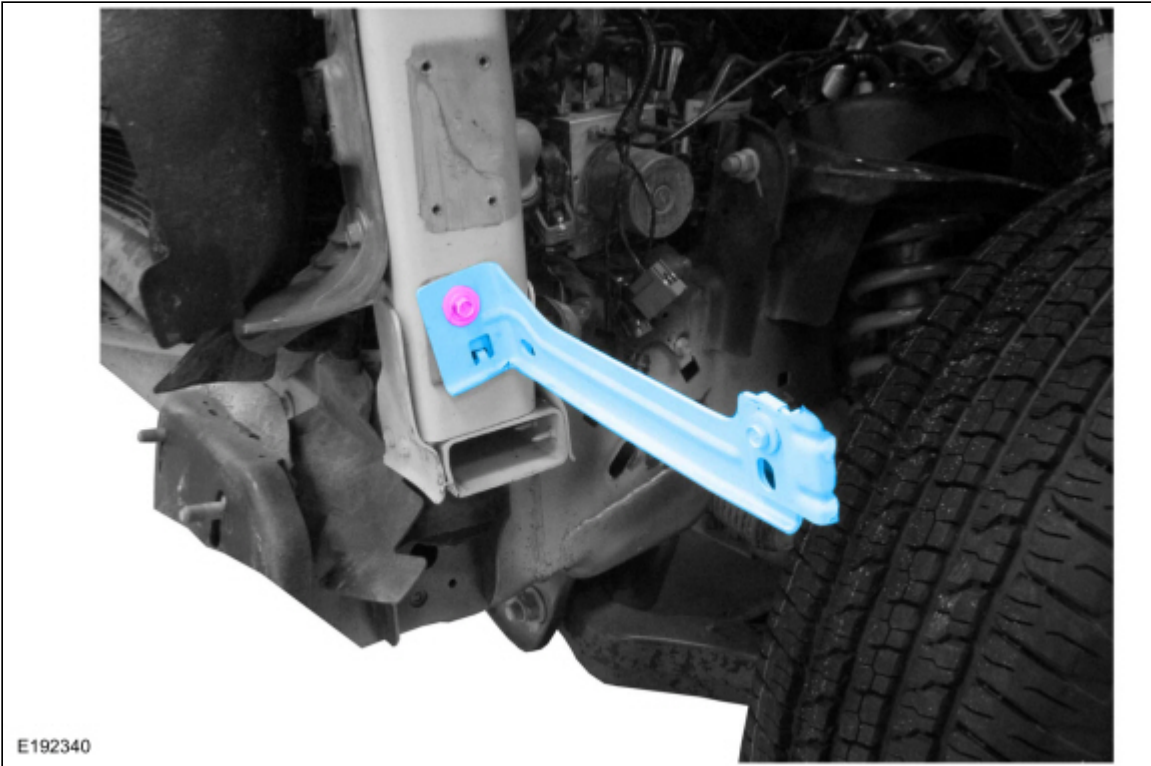

17. Reposition the wiring harness assembly.

18. LH side.
Refer to: [Battery](#) (414-01 Battery, Mounting and Cables, Removal and Installation).



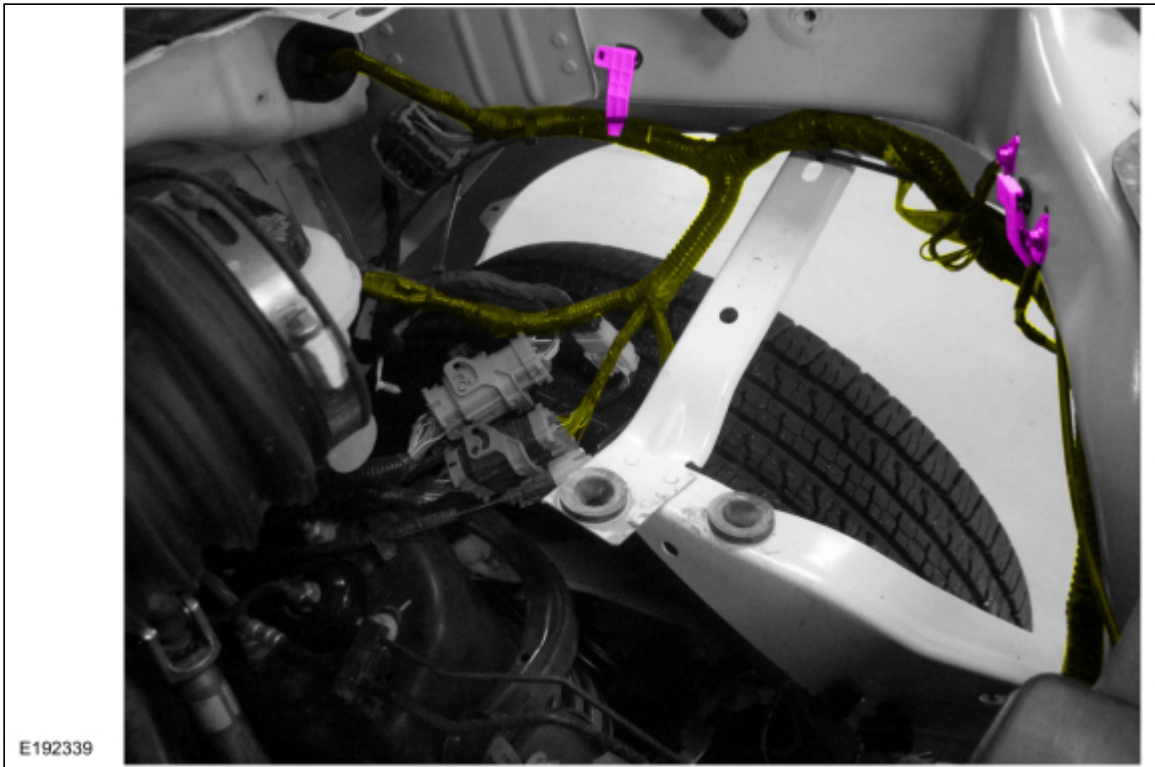

19. Install the air cleaner assembly.
Refer to: [Air Cleaner](#) (303-12A Intake Air Distribution and Filtering - 2.7L EcoBoost (238kW/324PS), Removal and Installation).
Refer to: [Air Cleaner](#) (303-12B Intake Air Distribution and Filtering - 3.3L Duratec-V6, Removal and Installation).
Refer to: [Air Cleaner](#) (303-12E Intake Air Distribution and Filtering - 5.0L 32V Ti-VCT, Removal and Installation).
Refer to: [Air Cleaner](#) (303-12E Intake Air Distribution and Filtering - 5.0L 32V Ti-VCT, Removal and Installation).
Refer to: [Air Cleaner](#) (303-12F Intake Air Distribution and Filtering - 3.0L Power Stroke Diesel, Removal and Installation).
20. Install the front bumper.
Refer to: [Front Bumper](#) (501-19 Bumpers, Disassembly and Assembly).
21. Install the hood and hood hinge on the repair side.
Refer to: [Hood](#) (501-02 Front End Body Panels, Removal and Installation).
22. Install the fender and fender splash shield.
Refer to: [Fender](#) (501-02 Front End Body Panels, Removal and Installation).
Refer to: [Fender Splash Shield](#) (501-02 Front End Body Panels, Removal and Installation).
23. Install the front door.
Refer to: [Front Door - Regular Cab/SuperCrew](#) (501-03 Body Closures, Removal and Installation).
Refer to: [Front Door - SuperCab](#) (501-03 Body Closures, Removal and Installation).
24. Repower the SRS.
Refer to: [Supplemental Restraint System \(SRS\) Repowering](#) (501-20B Supplemental Restraint System, General Procedures).

